



ED3701

ED3702

**DIRECTIONAL LEDs**

Beacons | Lightbars | Minibars | Worklamps | Back-Up Alarms | Camera Systems

## ED3701 & ED3702 Series

### SAE Class I Solid, Split & Dual Color Surface Mount

ED3701 and ED3702 directional LEDs are bright and versatile warning lights that are suited to a wide variety of applications. Their ultra-low profile makes them easy to install virtually anywhere on a vehicle. Both models offer wide angle optics and multiple flash patterns, including synchronization with other units for simultaneous or alternating operation. ED3701 models feature 6 LEDs and are available in either single color or split-color configurations (3 LEDs of each color). The ED3702 is a dual-color light featuring 12 LEDs (6 of each color) and available in 7 color configurations.

#### Models

PART NO.	COLORS	VDC	AMPS
ED3701A	Amber	12-24	0.9
ED3701B	Blue	12-24	0.9
ED3701C	Clear	12-24	0.9
ED3701G	Green	12-24	0.9
ED3701R	Red	12-24	0.9
ED3701AB	Amber/Blue	12-24	0.9
ED3701AC	Amber/Clear	12-24	0.9
ED3701AG	Amber/Green	12-24	0.9
ED3701AR	Amber/Red	12-24	0.9
ED3701BC	Blue/Clear	12-24	0.9
ED3701RB	Red/Blue	12-24	0.9
ED3701RC	Red/Clear	12-24	0.9
ED3702AB	Amber/Blue	12-24	1.5
ED3702AC	Amber/Clear	12-24	1.5
ED3702AG	Amber/Green	12-24	1.5
ED3702AR	Amber/Red	12-24	1.5
ED3702BC	Blue/Clear	12-24	1.5
ED3702RB	Red/Blue	12-24	1.5
ED3702RC	Red/Clear	12-24	1.5

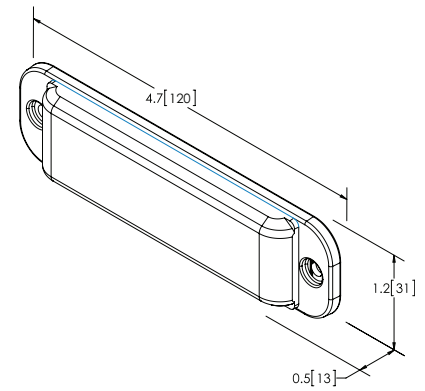

#### Features and Benefits

- Six or 12 high-intensity LEDs
- Ultra low-profile
- ED3701: single or split color options
- ED3702: dual color warning
- Single and split color models feature 13 flash patterns with 29 modes
- Dual color models feature 12 flash patterns with 62 modes
- Synchronizable
- Die cast base, polycarbonate lens
- Surface mount
- SAE J595 Class I
- California Title 13, R65, R10
- Temperature Range: -22°F to +122°F (-30°C to +50°C)
- Warranty: 3 years